



# RE-POWERING GUIDELINES

If replacing a Briggs & Stratton engine with a Briggs & Stratton engine, provide the original engine's model and type numbers to assure the correct replacement. If replacing a competitor's engine with a Briggs & Stratton engine, let the horsepower and features of the original engine plus the expected work cycle be a guide in selecting the correct replacement. Also consider these factors:

## 1. Engine Selection

Match the engine's performance and cost to your specific application to get the optimum performance at an affordable price. That means better value for you.

- **Vanguard™ OHV** (overhead valve) engines are maximum performance, cast iron cylinder sleeve engines – select for continuous heavy duty applications.
- **Industrial Plus™ and I/C®** (Industrial/Commercial) engines are cast iron cylinder sleeve, side valve engines – select for medium duty commercial, industrial and rental use.
- **Standard** engines are aluminum cylinder bore, side valve engines – select for general consumer use.

## 2. Safety Points

For many safe hours of operation, it is important to maintain the original engine's same horsepower, starter type and position, fuel tank location, fuel line routing, muffler location, exhaust direction and muffler accessories (i.e., deflector, spark arrestor, etc.). Reinstall all guards, shields and safety devices. Replace missing, worn or damaged parts.

## 3. Horizontal Crankshaft Engines

- Compare overall engine size for possible mounting interference
- Match crankshaft's
  - Diameter "A"
  - Height "B" (distance from base to crankshaft center line)
  - Length "C" (distance from oil seal/cover's mounting face to end of crankshaft)
- Match crankshaft type, i.e., keyway, tapered or threaded
- Match crankcase cover's tapped holes for mounting accessories (if applicable)
- Match base mounting dimensions and bolt holes spacing

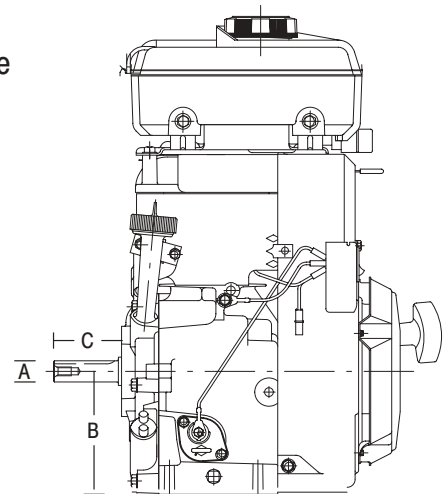

## 4. Vertical Crankshaft Engines

- Compare overall engine size for possible mounting interference
- Match starter type and starter grip position "A"
- Match crankshaft's
  - Diameter "B"
  - Keyway type "C"
  - Length "D" (distance from mounting face of sump – not oil seal – to end of crankshaft)
- Match mounting base dimensions and bolt holes spacing

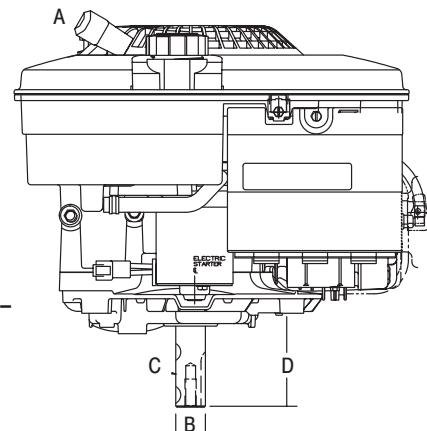

## SPECIFICATIONS OF SERVICE ENGINES

### LEGEND OF ABBREVIATIONS

STARTER POSITION:	Number shown is "o'clock" position of rewind starter. Spark plug is considered to be the 12 o'clock position.
OIL FILLER & DRAIN:	"CS" – carburetor side, "OC" – opposite carburetor, "D" – dual (both sides).
GOVERNOR:	"AV" – air vane, "M" – mechanical, "E" – electronic.
CONTROLS:	"MF" – manual friction, "R" – remote, "AG" – adjustable for a constant speed operation, "FC" – fixed speed control.
GROUND WIRE TERMINAL:	May be used with stop switch in remote location.
ACCESSORY MTG. BOSS or FLANGE MOUNTING:	Tapped holes in crankcase cover used to fasten clutch brackets, belt guards, etc.
DIMENSION:	Distance from end of crankshaft to one of the points listed below: (a) Oil seal on plain bearing horizontal crankshaft engines. (b) Mounting face of sump on vertical crankshaft engines. (c) Flange mounting face on horizontal crankshaft engines.
SHIPPING WEIGHT:	Gross Domestic Shipping Weight.

# 18 HP VANGUARD™ Model Series 350400

Displacement 34.75 cu. in. (570 cc)

Bore 2.83 in. (72 mm)

Stroke 2.75 in. (70 mm)

Oil Capacity:

48 fl. oz. (1.42 l) w/o Filter

56 fl. oz. (1.66 l) w/Filter



COMMERCIAL POWER



## Features:

- Dura-Bore™ cast iron cylinder sleeve for extended life
- Float carburetor for consistent easy starting
- Maintenance-free Magneton® electronic ignition for quick, dependable starts
- Dual-Clean™ air cleaner pleated paper filter with a foam pre-cleaner ensures maximum protection for extended engine life
- Full pressure lubrication with spin-on oil filter assures controlled lubrication for extended component life
- Overhead valve design (OHV) for cooler operation and longer valve life
- Buyer protection package provides two-year commercial engine warranty

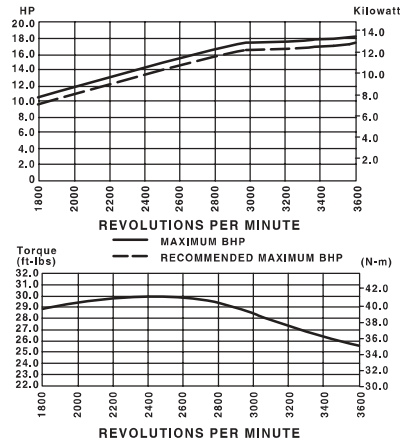
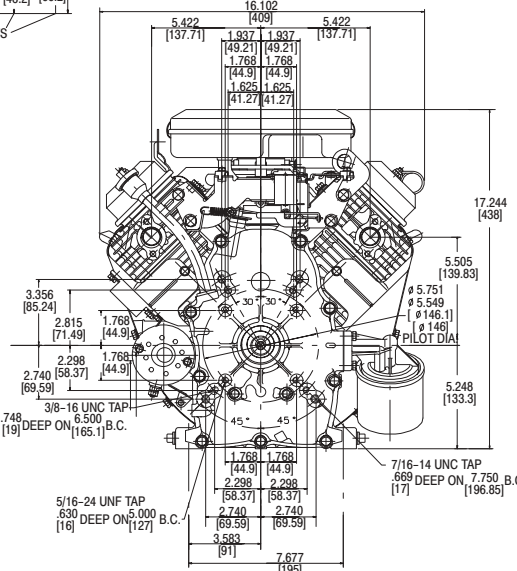
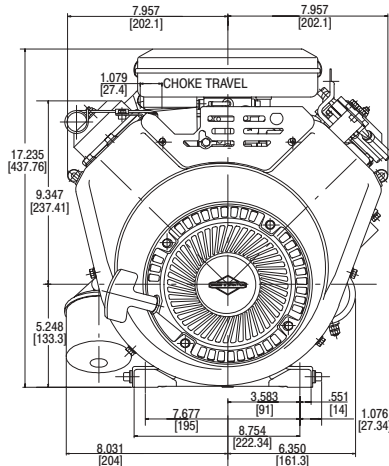
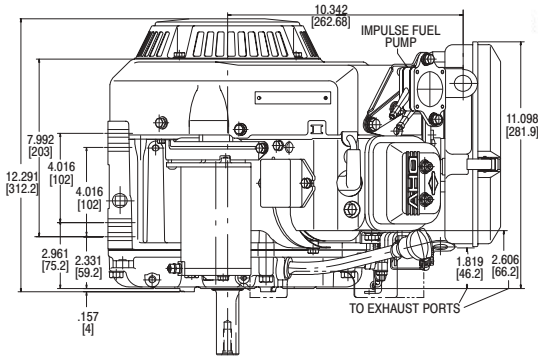

See Engine Accessories & Products Catalog Form MS-3880 for Exhaust Manifold and Muffler Options.

Model Type	Shipping Weight	Crankshaft	Crankshaft (P.T.O.) Extension	Dimension	Starter Position	Bolt-On/Changeable	Oil Filler & Drain	Governor	Controls	Exhaust System	Fuel Tank (Quarts)	Pulse Fuel Pump	Flange Mtg.	Oil Pump w/Filter	Manual & Remote Choke	Top Governor Speed	Notes
350442																	
1365	88	692171	1" dia., Keyway, tapped 3/8-24	2-29/32(c)	9	★	M	AG/R/MF	•	9	X	X	X	X	3600		
350447																	
1009	98	692171	1" dia., Keyway, tapped 3/8-24	2-29/32(c)	9	★	E	FC	•	9	X	X	X	X	3600	□	
1079	89	692171	1" dia., Keyway, tapped 3/8-24	2-29/32(c)	9	★	M	AG/R/MF	•	■	X	X	X	X	3600	◆	
1087	90	691139	1-1/8" dia., Keyway, tapped 7/16-20	4(c)	9	★	M	AG/R/MF	•	■	X	X	X	X	3600	◆	
1105	89	692173	Tapered, tapped 5/16-24	3-51/64(c)	9	★	E	FC	•	■	X	X	X		3600	◆	
1366	102	692171	1" dia., Keyway, tapped 3/8-24	2-29/32(c)	9	★	M	AG/R/MF	X	9	X	X	X	X	3600	◆	
1375	93	692171	1" dia., Keyway, tapped 3/8-24	2-29/32(c)	9	★	M	AG/R/MF	•	■	X	X	X	X	3600	◆	
1377	89	692170	Threaded 1-14, 1" thread length	3-21/32(c)	9	★	M	AG/R/MF	•	■	X	X	X	X	3600	◆	
1378	89	692173	Tapered, tapped 5/16-24	3-51/64(c)	9	★	M	AG	•	■	X	X	X		3750	◆	
1396	96	692171	1" dia., Keyway, tapped 3/8-24	2-29/32(c)	9	★	M	AG/R/MF	•	9	X	X	X	X	3600	◆	

★ Oil fill and dipstick in cover; dual drain.      ◆ Engine equipped with 12 Volt Gear Drive Starter and 16 Amp DC Alternator with Starter Panel Assembly.  
 □ Engine equipped with 12 Volt Gear Drive Starter and 20 Amp DC Alternator with Starter Panel.      ■ Fuel tank omitted.      ● Exhaust manifold and muffler omitted.

## YOUR KEY TO THE WORLD'S FINEST ENGINES

This chart explains the unique Briggs & Stratton numerical model designation system. It is possible to determine most of the important mechanical features of the engine by merely knowing the model number. Here is how it works:

- A. The first one or two digits indicate the approximate CUBIC INCH DISPLACEMENT.
- B. The first digit after the displacement indicates the BASIC DESIGN SERIES, relating to cylinder construction, ignition, general configuration, etc.
- C. The second digit after the displacement indicates ORIENTATION OF CRANKSHAFT.
- D. The third digit after the displacement indicates TYPE OF BEARINGS, and whether or not the engine is equipped with REDUCTION GEAR or AUXILIARY DRIVE.
- E. The last digit indicates the TYPE OF STARTER.

### BRIGGS & STRATTON MODEL NUMBERING SYSTEM

<u>A</u>	<u>B</u>	<u>C</u>	<u>D</u>	<u>E</u>
FIRST DIGIT AFTER DISPLACEMENT	SECOND DIGIT AFTER DISPLACEMENT	THIRD DIGIT AFTER DISPLACEMENT	FOURTH DIGIT AFTER DISPLACEMENT	
CUBIC INCH DISPLACEMENT	BASIC DESIGN SERIES	CRANKSHAFT ORIENTATION	PTO BEARING, REDUCTION GEAR, AUXILIARY DRIVE, LUBRICATION	TYPE OF STARTER
6	0	0 to 4 - Horizontal Shaft	0 - Plain Bearing/DU Non-Flange Mount	0 - Without Starter
8	1	5 to 9 - Vertical Shaft		1 - Rope Starter
9	2		1 - Plain Bearing Flange Mounting	2 - Rewind Starter
10	3	A to G - Horizontal Shaft		3 - Electric Starter Only 110 or 230 Volt Gear Drive
11	4	H to Z - Vertical Shaft		
12	5		2 - Sleeve Bearing Flange Mounting Splash Lube	4 - Electric Starter/110 or 230 Volt Gear Drive with Alternator
13	6			
16	7			
18	8		3 - Ball Bearing Flange Mounting Splash Lube	5 - Electric Starter Only 12 or 24 Volt Gear Drive
19	9			
20	A to Z			
21			4 - Ball Bearing Flange Mounting Pressure Lubrication	6 - Alternator Only
22				
23			5 - Plain Bearing Gear Reduction (6 to 1) CCW Rotation Flange Mounting	7 - Electric Starter 12 or 24 Volt Gear Drive with Alternator
24				
25				
28				
29				
30			6 - Plain Bearing Gear Reduction (2 to 1) CCW Rotation	8 - Vertical Pull Starter or Side Pull Starter
31				
32				
35			7 - Plain Bearing Pressure Lubrication	9 - Mechanical Starter
38				
40				
42			8 - Plain Bearing Auxiliary Drive (PTO) Perpendicular to Crankshaft	A - Electric Starter 12 or 24 Volt Gear Drive with Alternator and Inverter
43				
44				
46				
47				
52			9 - Plain Bearing Auxiliary Drive Parallel to Crankshaft	
54				
58			A - Plain Bearing Pressure Lubrication Without Oil Filter	

EXAMPLE - To identify Model 303447:

<u>30</u>	<u>3</u>	<u>4</u>	<u>4</u>	<u>7</u>
30 Cubic Inch	Design Series 3	Horizontal Shaft	Ball Bearing Flange Mounting Pressure Lubrication	Electric Starter 12 or 24 Volt Gear Drive with Alternator

**TYPE 1234-01**, The type number identifies the engines mechanical parts, color of paint, decals, governed speed, and Original Equipment Manufacturer.

**CODE 01061201**, The code is the manufacturing date and is read as follows:

<u>YEAR</u>	<u>MONTH</u>	<u>DAY</u>	<u>ASSEMBLY LINE AND MANUFACTURING PLANT</u>
01	06	12	01

# BRIGGS & STRATTON ENGINE OWNER WARRANTY POLICY

Effective January 1, 2003 replaces all undated Warranties and all Warranties dated before January 1, 2003

## LIMITED WARRANTY

Briggs & Stratton Corporation will repair or replace, free of charge, any part(s) of the engine that is defective in material or workmanship or both. Transportation charges on parts submitted for repair or replacement under this warranty must be borne by purchaser. This warranty is effective for the time periods and subject to the conditions stated below. For warranty service, find the nearest Authorized Service Dealer in our dealer locator map at [www.briggsandstratton.com](http://www.briggsandstratton.com), or by calling 1-800-233-3723, or as listed in the "Yellow Pages"™.

THERE IS NO OTHER EXPRESS WARRANTY. IMPLIED WARRANTIES, INCLUDING THOSE OF MERCHANTABILITY AND FITNESS FOR A PARTICULAR PURPOSE, ARE LIMITED TO ONE YEAR FROM PURCHASE, OR TO THE EXTENT PERMITTED BY LAW ANY AND ALL IMPLIED WARRANTIES ARE EXCLUDED. LIABILITY FOR INCIDENTAL OR CONSEQUENTIAL DAMAGES ARE EXCLUDED TO THE EXTENT EXCLUSION IS PERMITTED BY LAW. Some states or countries do not allow limitations on how long an implied warranty lasts, and some states or countries do not allow the exclusion or limitation of incidental or consequential damages, so the above limitation and exclusion may not apply to you. This warranty gives you specific legal rights and you may also have other rights which vary from state to state and country to country.

## OUR PRODUCT

<b>VANGUARD™</b>	<b>ELS™ I/C® Industrial Plus™ Intek™ (Sleeve Bore)</b>	<b>Fource™ Intek™ (Kool Bore) Power Built™ OHV QUANTUM® Quattro™ Q45™ Sprint™</b>	<b>Classic™</b>	<b>Etek™</b>
------------------	--	---	-----------------	--------------

## WARRANTY PERIOD\*

Consumer Use	2 years	2 years	2 years	1 year	1 year
Commercial Use		1 year	90 days	90 days	

\* Note the following special warranty periods: **2 years** for Classic™ engines in the European Union and Eastern European countries, for all consumer products in the European Union, and for emission control systems on engines certified by EPA and CARB. **5 years** for consumer use, 90 days for commercial use of Touch-N-Mow® starter on Quantum® and Intek™ engines. **Engines used in competitive racing or on commercial or rental tracks are not warranted.**

The warranty period begins on the date of purchase by the first retail consumer or commercial end user, and continues for the period of time stated in the table above. "Consumer use" means personal residential household use by a retail consumer. "Commercial use" means all other uses, including use for commercial, income producing or rental purposes. Once an engine has experienced commercial use, it shall thereafter be considered as a commercial use engine for purposes of this warranty.

**NO WARRANTY REGISTRATION IS NECESSARY TO OBTAIN WARRANTY ON BRIGGS & STRATTON PRODUCTS. SAVE YOUR PROOF OF PURCHASE RECEIPT. IF YOU DO NOT PROVIDE PROOF OF THE INITIAL PURCHASE DATE AT THE TIME WARRANTY SERVICE IS REQUESTED, THE MANUFACTURING DATE OF THE PRODUCT WILL BE USED TO DETERMINE THE WARRANTY PERIOD.**

## ABOUT YOUR ENGINE WARRANTY

Briggs & Stratton welcomes warranty repair and apologizes to you for being inconvenienced. Any Authorized Service Dealer may perform warranty repairs. Most warranty repairs are handled routinely, but sometimes requests for warranty service may not be appropriate. For example, warranty would not apply if engine damage occurred because of misuse, lack of routine maintenance, shipping, handling, warehousing or improper installation. Similarly, warranty is void if the serial number of the engine has been removed or the engine has been altered or modified.

If a customer differs with the decision of the Service Dealer, an investigation will be made to determine whether the warranty applies. Ask the Service Dealer to submit all supporting facts to his Distributor or the Factory for review. If the Distributor or the Factory decides that the claim is justified, the customer will be fully reimbursed for those items that are defective. To avoid misunderstanding which might occur between the customer and the Dealer, listed below are some of the causes of engine failure that the warranty does not cover.

### Normal wear:

Engines, like all mechanical devices, need periodic parts service and replacement to perform well. Warranty will not cover repair when normal use has exhausted the life of a part or an engine.

### Improper maintenance:

The life of an engine depends upon the conditions under which it operates, and the care it receives. Some applications, such as tillers, pumps and rotary mowers, are very often used in dusty or dirty conditions, which can cause what appears to be premature wear. Such wear, when caused by dirt, dust, spark plug cleaning

grit, or other abrasive material that has entered the engine because of improper maintenance, is not covered by warranty.

**This warranty covers engine related defective material and/or workmanship only, and not replacement or refund of the equipment to which the engine may be mounted. Nor does the warranty extend to repairs required because of:**

1. PROBLEMS CAUSED BY PARTS THAT ARE NOT ORIGINAL BRIGGS & STRATTON PARTS.
2. Equipment controls or installations that prevent starting, cause unsatisfactory engine performance, or shorten engine life. (Contact equipment manufacturer.)
3. Leaking carburetors, clogged fuel pipes, sticking valves, or other damage, caused by using contaminated or stale fuel. (Use clean, fresh, lead-free gasoline and Briggs & Stratton Fuel Stabilizer, Part No. 5041.)
4. Parts which are scored or broken because an engine was operated with insufficient or contaminated lubricating oil, or an incorrect grade of lubricating oil (check oil level daily or after every 8 hours of operation. Refill when necessary and change at recommended intervals.) OIL GARD® may not shut down running engine. Engine damage may occur if oil level is not properly maintained. Read Operating & Maintenance Instructions.
5. Repair or adjustment of associated parts or assemblies such as clutches, transmissions, remote controls, etc., which are not manufactured by Briggs & Stratton.
6. Damage or wear to parts caused by dirt, which entered the engine because of improper air cleaner maintenance, re-assembly, or use of a non-original air cleaner element or cartridge. (At recommended intervals, clean and re-oil

the Oil-Foam® element or the foam pre-cleaner, and replace the cartridge.) Read Operating & Maintenance Instructions.

7. Parts damaged by over-speeding, or overheating caused by grass, debris, or dirt, which plugs or clogs the cooling fins, or flywheel area, or damage caused by operating the engine in a confined area without sufficient ventilation. (Clean fins on the cylinder, cylinder head and flywheel at recommended intervals.) Read Operating & Maintenance Instructions.
8. Engine or equipment parts broken by excessive vibration caused by a loose engine mounting, loose cutter blades, unbalanced blades or loose or unbalanced impellers, improper attachment of equipment to engine crankshaft, over-speeding or other abuse in operation.
9. A bent or broken crankshaft, caused by striking a solid object with the cutter blade of a rotary lawn mower, or excessive v-belt tightness.
10. Routine tune-up or adjustment of the engine.
11. Engine or engine component failure, i.e., combustion chamber, valves, valve seats, valve guides, or burned starter motor windings, caused by the use of alternate fuels such as, liquified petroleum, natural gas, altered gasolines, etc.

**Warranty is available only through service dealers which have been authorized by Briggs & Stratton Corporation. your nearest Authorized Service Dealer is listed in the "Yellow Pages"™ of your telephone directory under "Engines, Gasoline" or "Gasoline Engines," "Lawn Mowers," or similar category.**

Briggs & Stratton Engines Are Made Under One Or More Of The Following Patents: Design D-247,177 (Other Patents Pending)

6,325,036	6,077,063	5,819,513	5,606,948	5,497,679	5,235,943	5,138,996	4,996,956	4,633,556	4,430,984	DES. 308,871
6,284,123	6,064,027	5,813,384	5,606,851	5,320,795	5,197,425	5,086,890	4,977,879	4,630,498		DES. 308,872
6,260,529	6,014,808	5,765,713	5,548,955	5,271,363	5,197,422	5,070,829	4,971,219	4,522,080		DES. 309,457
6,230,678	5,894,715	5,645,025	5,546,901	5,269,713	5,191,864	5,058,544	4,895,119	4,520,288		DES. 356,951
6,202,616	5,852,951	5,642,701	5,503,125	5,265,700	5,188,069	5,040,644	4,819,593	4,512,499		DES. 361,771
6,116,212	5,823,153	5,619,845	5,501,203	5,243,878	5,186,142	5,009,208	4,719,682	4,453,507		DES. 375,963